

GN 961

Angle pieces for profile systems

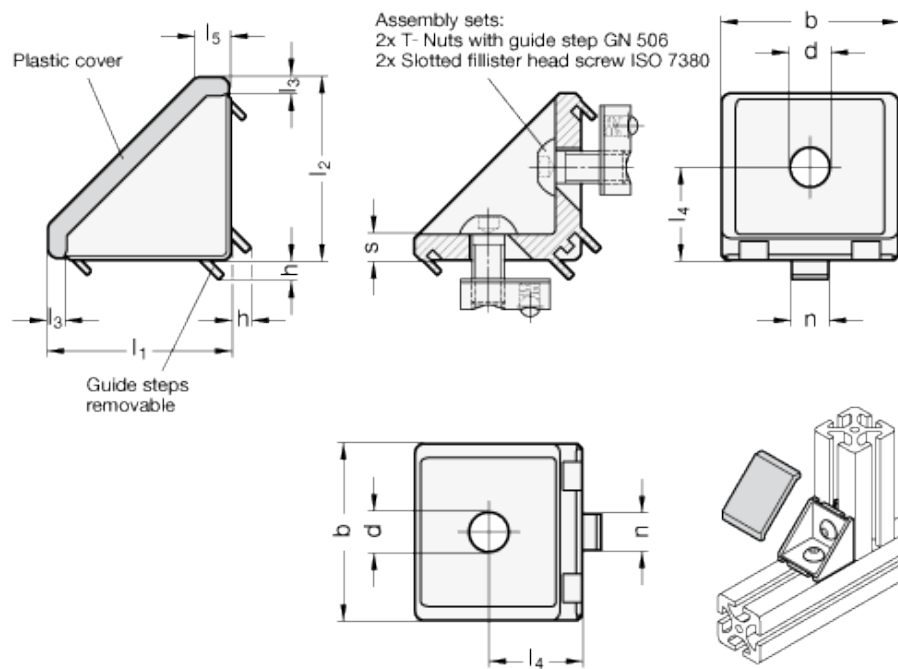

technical informations

Specification

Types

- Type A: without assembly set, with cover
- Type B: with assembly set, with cover
- Type C: with assembly set, without cover

Aluminium

Die casting

- matt shot-blasted MT
- plastic coated

black, RAL 9005, textured finish SW
silver, RAL 9006, textured finish SR

T-Nuts with guide step GN 506

Steel

zinc plated, blue passivated

Slotted fillister head screw ISO 7380
Steel
zinc plated, blue passivated

Cover
Plastic (Polyamide PA)
black, matt

Information

To fix the angle pieces GN 961 in place, first insert the nuts of the assembly set into the profile slot and fix the angle piece with the slotted fillister head screw. The guide step of the nut will then position these in parallel and centered to the slot; the spring element counteracts inadvertent sideways slip.

For crossing profiles or when using the angle piece with elements without slot, the superfluous guide steps can be simply broken out.

After assembly, the cover caps are snapped into place via four lugs. They lend the angle piece an attractive appearance and protect against dirt.

Even after repeated use, the cover caps will remain firmly in place inside the angle pieces thanks to the elastic snap-type lugs. If required, these are also available individually under standard GN 963.

Standard Elements	Main dimensions											Weight
Description	b _{Nominal size}	Actual size	n	l ₁	l ₂	d	h	l ₃	l ₄	l ₅	s	g
GN 961-30-6-30-30-A-MT	30	28	6	30	30	6.3	2.6	-	15	-	5.9	23
GN 961-30-6-30-30-A-SW	30	28	6	30	30	6.3	2.6	-	15	-	5.9	23
GN 961-30-6-30-30-A-SR	30	28	6	30	30	6.3	2.6	-	15	-	5.9	23
GN 961-40-8-40-40-A-MT	40	38	8	40	40	8.5	4.1	-	20	-	5.6	39
GN 961-40-8-40-40-A-SW	40	38	8	40	40	8.5	4.1	-	20	-	5.6	39
GN 961-40-8-40-40-A-SR	40	38	8	40	40	8.5	4.1	-	20	-	5.6	39
GN 961-30-6-30-30-B-MT	30	28	6	30	30	6.3	2.6	3	15	6.8	5.9	23
GN 961-30-6-30-30-B-SW	30	28	6	30	30	6.3	2.6	3	15	6.8	5.9	23
GN 961-30-6-30-30-B-SR	30	28	6	30	30	6.3	2.6	3	15	6.8	5.9	23
GN 961-40-8-40-40-B-MT	40	38	8	40	40	8.5	4.1	4	20	7.2	5.6	39
GN 961-40-8-40-40-B-SW	40	38	8	40	40	8.5	4.1	4	20	7.2	5.6	39
GN 961-40-8-40-40-B-SR	40	38	8	40	40	8.5	4.1	4	20	7.2	5.6	39
GN 961-30-6-30-30-C-MT	30	28	6	30	30	6.3	2.6	-	15	-	5.9	23
GN 961-30-6-30-30-C-SW	30	28	6	30	30	6.3	2.6	-	15	-	5.9	23
GN 961-30-6-30-30-C-SR	30	28	6	30	30	6.3	2.6	-	15	-	5.9	23
GN 961-40-8-40-40-C-MT	40	38	8	40	40	8.5	4.1	-	20	-	5.6	39
GN 961-40-8-40-40-C-SW	40	38	8	40	40	8.5	4.1	-	20	-	5.6	39
GN 961-40-8-40-40-C-SR	40	38	8	40	40	8.5	4.1	-	20	-	5.6	39



STANDARD MACHINE ELEMENTS WORLDWIDE